



ITT

Water & Wastewater

# Flygt Widethroat W Range



*Engineered for life*

# The Flygt Widethroat W Range



## Features and Benefits

The design of the Flygt W range is such that many different applications can be handled. The standard design consists of an enlarged rectangular inlet with a screw conveyor to assist the product into the pumping element. Options exist that can modify the inlet with either large diameter augers, integral bridge breakers or both.

Pumps are available close coupled or as a bare-shaft pump.

Dry solids approaching 40% can be handled by the pumps when fitted with either the integral bridge breakers or large augers.

The pump has been designed to facilitate maintenance through its simple design and the use of a plug in shaft facility.

The pumps are available in a range of materials to ensure a wide variety of products can be handled. Shaft sealing is a hard faced, single mechanical seal, with packed gland available as an option.

## Flygt Widethroat W Range

The Flygt Widethroat range has been designed to handle highly viscous materials such as sludges, slurries, thick non-flowing pastes and de-watered sludge cake with viscosities up to 1,000,000 cP. The range is based on single, two, four, six and eight stage pumps which can develop pressures up to 48 bar and capacities up to 215m<sup>3</sup>/h.

For the many difficult and varied applications encountered, the pumps are run at a relatively slow speed, therefore the pump will handle shear sensitive products with minimal product damage, abrasive solids in suspension and highly viscous materials.

## Typical Performance Data for the Flygt Widethroat W range

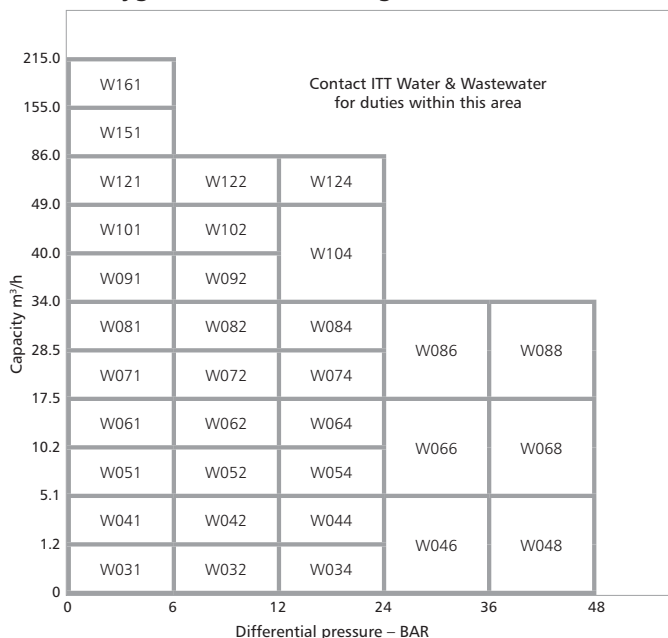

## NOTES:

1. The tabulated performance data shown is based upon handling clean water at 20°C.
2. For guidance in selection of a pump for use with other fluids of varying abrasion and viscosity refer to ITT Water & Wastewater.

# Applications



A W064 model installed at a sewage treatment works to control sewage odours, caused by a belt press feeding dewatered sludge cake directly onto an open-air conveyor and into an open skip for disposal. The

cast iron W064, with an integral bridge breaker fitted as an option, delivers the sludge cake at the required rate of 2.5m<sup>3</sup>/h and pressures of up to 12 bar. It operates eight hours per day, six days a week and daily fills up the four enclosed skips with sludge cake.



A total of 9 stainless steel W range pumps have been installed at a plant in Greenwich to handle highly viscous materials and transfer it along several hundred metres of pipework. Operating at speeds of between 123rpm and

196rpm, delivering gluten at a capacity of 4.5m<sup>3</sup>/h to 40.5m<sup>3</sup>/h and pressures of 3 to 8 bar. Extreme reliability was specified by the customer, as the pumps have to operate 24 hours a day, seven days a week with minimum downtime for repairs.



Problems arose at a water treatment works with the discharge of sludge cake by chute into a mobile skip for disposal on landfill sites. As the sludge is a relatively immobile solid, the only way to load the

skip evenly was by manually raking it out. The installation of a W054 pump loads the skip via a 15 metre long, 150mm diameter flexible hose, and the non-pulsating nature of the pump provides an even output of 1.5m<sup>3</sup>/h. As the pump operates at a pressure of 1 bar, it compresses the cake still further. Significant cost savings are achieved as a result – the skip now holds 6 tonnes rather than 4.5.



This site's sludge dewatering unit, installed at a large sewage treatment works, is a belt thickening system, comprising 3 x 3m wide belt of 0.7mm mesh, located above a collection sump. As the dewatered

sludge reaches the end of the belt it is deposited into the inlet hopper of the W072 pump and transferred to holding tanks at 14m<sup>3</sup>/h. Ideal for thick non-flowing sludges and slurries the W range incorporates an auger system which help to feed the sludge to the pumping element without bridging or blocking.



# Flygt W Range Dimensions

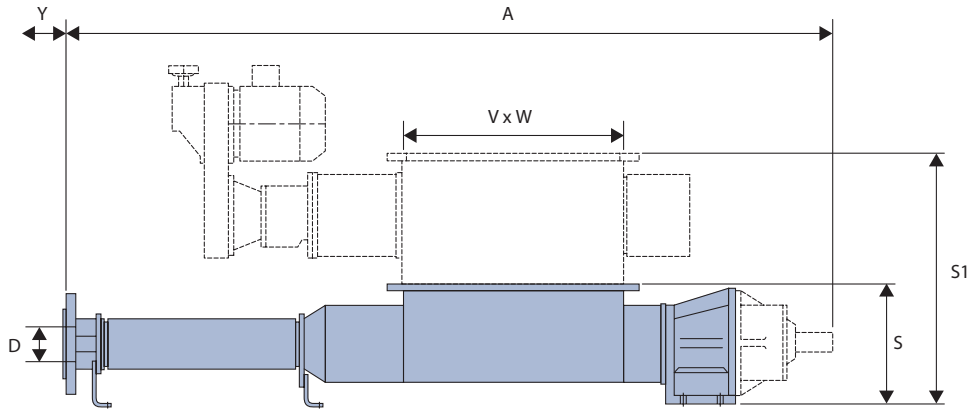

MODEL	STANDARD + BRIDGE BREAKER			STD	BRIDGE BREAKER	LARGE AUGER				ALL MODELS
	Y	A	VxW	S	S1	Y	A	VxW	S	D
W032	720	1156	320 x 170	185						
W034	750	1638	320 x 170	212						
W041	835	1324	350 x 250	232						
W042	835	1523	350 x 250	232	412	770	1842	750 x 250	282	65
W044	890	1987	350 x 250	245	425	880	2293	750 x 250	295	80
W051	1045	1594	500 x 250	247						
W052	1050	1859	500 x 250	260	435	770	2010	750 x 250	310	80
W054	1100	2500	500 x 250	285	460	765	2657	750 x 503	35	100
W061	1265	1845	650 x 360	285						
W062	1270	2249	650 x 360	310	515	1030	2484	1000 x 603	75	100
W064	1330	2964	650 x 360	320	525	1035	3212	1000 x 360	395	125
W071	1300	2034	650 x 360	330						
W072	1300	2402	650 x 360	330	525	1025	2675	1000 x 604	15	125
W081	1300	2078	650 x 360	330						
W082	1370	2581	650 x 360	340	550	1040	2865	1000 x 360	505	125
W084	1440	3590	650 x 360	405	615	1030	3847	1000 x 605	05	150
W091	1550	2407	800 x 450	360						
W092	1550	2869	800 x 450	360	575	1045	3053	1000 x 505	05	150
W101	1550	2485	800 x 450	360						
W102	1625	3153	800 x 450	405	655	1042	3410	1000 x 505	50	150
W121	1600	2784	800 x 450	450						

## NOTES:

1. All dimensions in millimetres unless otherwise stated and for guidance only. For full certified drawings refer to ITT Water & Wastewater.
  2. Shaft diameters are to BS 4506: 1970 and keyways to ISO R773.
  3. End Cover dimensions to BS EN 1092.
  4. Dimension Y is the preferred dismantling space. Consult ITT Water & Wastewater for minimum dismantling space.
  5. Please refer to ITT Water & Wastewater, for hopper drilling details.
  6. V&W – Standard hopper size. For extended hopper sizes, please refer to ITT Water & Wastewater.
  7. For models and dimensions not shown above, please contact ITT Water & Wastewater.
- \* 11/2" BSP outlet provided

# Here's how we complete the picture

## **Flygt monitoring and control improves the uptime of your wastewater treatment plant leading to lower operational costs.**

We supply both the hardware and the software for complete process systems – ranging from SCADA, process and pump controllers to pump drives, start equipment and sensors through to system software. With smart monitoring and control, you benefit from predictive maintenance. Our system automatically alerts you at an early stage when service is required, and signaling when corrective actions are necessary. This effectively eliminates unnecessary emergency service calls and cuts both operating and maintenance costs.

And Flygt Monitoring & Control is easy to use. Settings can be changed quickly by simply adjusting the values on the display on the controller, on the central system or even on a laptop from wherever a user happens to be.



## Your worldwide service network



Because no two pumping stations or systems are alike, ITT Water & Wastewater lets you choose the type of support package that best matches your needs. At one end, we help in selecting the right pump for a new application. At the other end, we can provide full service assistance that includes everything from system planning and design, through construction and commissioning, to operation and maintenance.

### **Extensive spare parts guarantee**

With a worldwide network of authorized service centers, you always get the support you need: whether it's a question of planned maintenance or express part delivery.

We also guarantee the availability of spare parts 20 years after we stop production of a pump model. This is just one of the ways we demonstrate our long-term commitment to our customers.



### **What can ITT Water & Wastewater do for you?**

ITT Water & Wastewater is a global provider of water handling and treatment solutions for municipal and industrial customers in more than 140 countries. ITT designs and delivers energy-efficient solutions and related services for water and wastewater transport, biological treatment, filtration and disinfection. The company employs nearly 5,000 people through its global sales network, manufacturing sites in Europe, Asia and the Americas, and global headquarters in Stockholm, Sweden. ITT Water & Wastewater is a business of ITT Corporation, a high-technology engineering and manufacturing company operating in three vital markets: water and fluids management, global defence and security, and motion and flow control.

[www.ittwww.com](http://www.ittwww.com)



**WEDECO**

